

MILITARY SPECIFICATION SHEET

RECEPTACLE, ELECTRICAL, 40-AMPERE, 125-VOLT,
SINGLE POLE, PANEL MOUNTED, FEMALE
(SYMBOL NO. 1213.2 - RED; SYMBOL NO. 1213.4 - BLACK)

- (B) This specification is approved for use within the Naval Sea Systems Command, Department of the Navy, and is available for use by all Departments and Agencies of the Department of Defense.
- (B) The requirements for acquiring the receptacle described herein shall consist of this specification and the latest issue of MIL-R-2726.

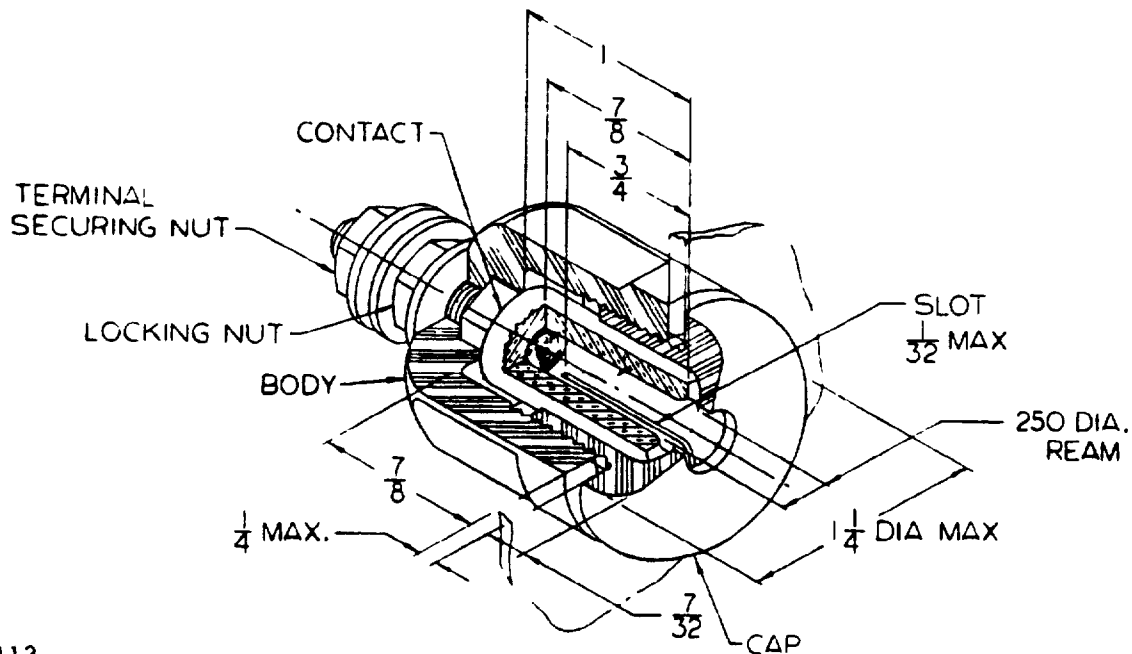

SH 9113

NOTES:

1. Dimensions are in inches. Unless otherwise specified, tolerances are $\pm 1/64$ inch for fractions and ± 0.005 inch for decimals.
2. Supersedes: Drawing 9000-S6202-73338, symbol 1213.

FIGURE 1. Dimensions and configuration.

(B) denotes changes.

AMSC N/A

FSC 5935

DISTRIBUTION STATEMENT A Approved for public release; distribution unlimited

MIL-R-2726/35B(SH)

REQUIREMENTS:

1. Dimensions and configuration: See figure 1.
2. Contact resistance: When tested as specified in 4.7.3 of MIL-R-2726, the voltage drop shall not exceed 20 millivolts. Measured between the end of a 12-inch length of AWG number 6 stranded copper wire, properly connected to the test plug, and the connection stud of the receptacle.
3. Uncoupling force: Minimum of 8 pounds; maximum of 20 pounds.
4. H.I. shock: Disengagement of the test plug from its test receptacle under H.I. shock shall not be considered as a failure.
5. Contact hardness: Minimum of Rockwell 76B.
6. Mating plug: MIL-R-2726/33, part number M2726/33-001 - red; part number M2726/33-002 - black (not furnished).
7. Design: Panel hole - 29/32-inch diameter. Panel thickness - 1/16 to 1/4 inch.
8. Material: Body and cap - rubber, in accordance with ASTM D 2000 M2AC 710 A13E034 or plastic, in accordance with type MAI-60 of MIL-M-14.
9. Electrical rating: 40-ampere, 125-volt, single pole.
10. Part numbers: M2726/35-001 - (red) symbol 1213.2, M2726/35-002 - (black) symbol 1213.4.
11. Contact finish: Silver plate.

QUALITY ASSURANCE:

Quality assurance shall be as specified in MIL-R-2726 and table I herein. The first article and quality conformance inspections shall consist of the inspections as specified in table I, in the order shown.

TABLE I. First article and quality conformance inspection.

Inspection	Requirement	Test method	First article	Quality conformance
Examination	3.1, 3.3, 3.4, 3.5, 3.6 and 3.7	4.6.1	X	X
Insulation resistance	3.5.1	4.7.1	X	X
Dielectric withstanding voltage	3.5.2	4.7.2	X	X
Contact resistance	3.5.3.1	4.7.3.1	X	X
Uncoupling force	3.5.6	4.7.6	X	X
Endurance	3.5.5	4.7.5	X	
Uncoupling force	3.5.6	4.7.6	X	
Salt spray	3.5.11	4.7.11	X	
Contact resistance	3.5.3.1	4.7.3.1	X	
Current load	3.5.12	4.7.12	X	
Vibration	3.5.9	4.7.9	X	
Shock	3.5.10	4.7.10	X	
Dielectric withstanding voltage	3.5.2	4.7.2	X	
Rockwell hardness	3.5.14	4.7.14	X	

MIL-R-2726/35B(SH)

Preparing activity:

Navy - SH

(Project 5935-N255-36)